

Hydrostatic lead screws and corresponding bearing

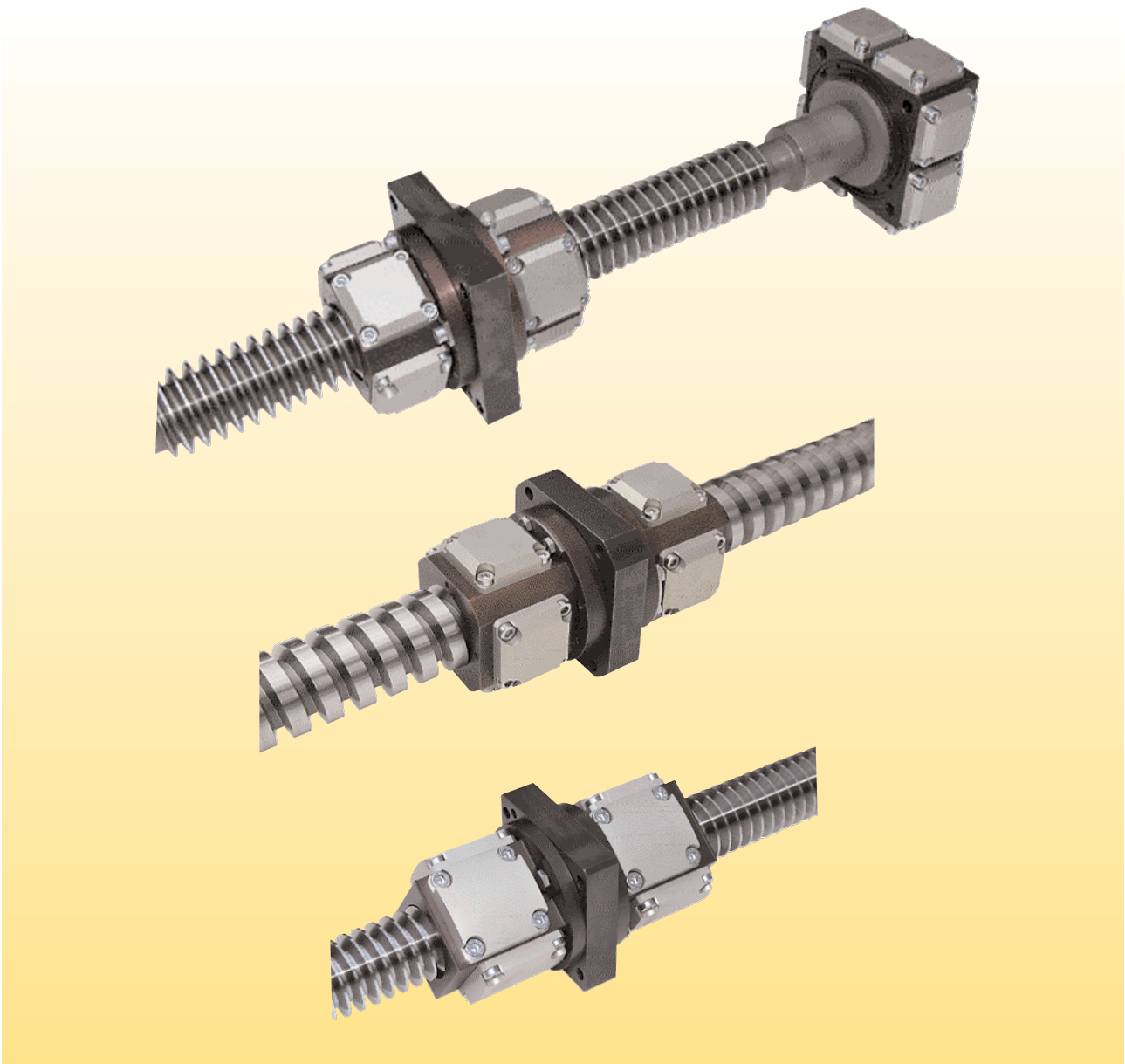

Table of Contents

1.	■ Lead screw with hydrostatic nut or ballscrew?	4
2.	■ Embodiments of the hydrostatic lead screw	4
2.1	Radial load capacity of the hydrostatic nut	4
2.2	Threaded spindle fixed on both sides	4
2.3	Rotating threaded spindle or rotating nut?	4
2.4	Means of fixing the hydrostatic nut for a rotating threaded spindle	5
2.5	Lead screw for high slide speeds	5
3.	■ Advantages of using our PM regulator	5
4.	■ Design factors	6
4.1	Oil supply to and oil discharge from the hydrostatic nut	6
4.2	Self-locking	6
4.3	Installation space and installation position	6
4.4	Crash safety	6
5.	■ Technical Data	6
5.1	Main dimensions and technical data	6
5.2	Dimensions of the flange nuts	7
5.2.1	Flange nut with round fastening flange	7
5.2.2	Flange nut with square fastening flange	8
5.3	Load capacity and stiffness	9
5.4	Some example values for oil supply, leakage power and speed	9
6.	■ Usage and installation of lead screws with hydrostatic nut	9
6.1	Delivery of the lead screw	9
6.2	Assembly of the lead screw	10
6.3	Installation and adjustment of the hydrostatic lead screw	10
6.4	Installation tolerances	10
7.	■ Hydrostatic bearing for lead screw	11
7.1	Bearing for lead screw with 4 regulators	11
7.2	Bearing for lead screw with 8 regulators	12
	■ Summary of the benefits of the hydrostatic lead screw	
	Hydrostatic lead screws	14
	Hydrostatic bearing for lead screw	15
	■ Hydrostatic lead screw in comparison	
	to linear motor and ballscrew	16

1. Lead screw with hydrostatic nut or ballscrew?

Due to the necessary ball deflection and the form and dimensional errors of ball running tracks, high quality ball screws even show greatly different torques for small position changes. In addition, oscillations are produced by the ball deflections, which can be detected at high speeds as the “well-known noise of ballscrews”.

Furthermore, the ballscrews are characterised by a jump in the drive torque during the change in the movement direction whose size increases in proportion to the stiffness requirements. Further, a defective vibration damping and a limited service life of the spindle must particularly be assumed if only a small path range is heavily loaded when high forces should be transmitted at low speeds or if high accelerations occur.

The lead screw with hydrostatic nut, as described in the following, has been developed in order to avoid these

disadvantages. This nut is distinguished by excellent damping, being wear-free, low friction torque, which increases approximately in proportion to the speed, and magnificent quiet running. Furthermore, no jump in the torque during change of the movement direction is produced whereby the highest positioning accuracy and track constancy are achieved. If desired, the stiffness of the nut can be designed significantly higher than for comparable ballscrew nuts.

A modified trapezoidal thread with 20° thread angle was selected as the thread for the hydrostatic nut.

By selecting the appropriate thread diameter, the number of the supporting runs of the nut, the pump pressure, the oil viscosity and the size of the oil flow, the threaded spindle can be adapted as far as possible to different requirements such as stiffness, speed and load. ■

2. Embodiments of the hydrostatic lead screw

2.1 Radial load capacity of the hydrostatic nut

The hydrostatic nuts are fitted with four hydrostatic pockets per thread run. The spindle is guided into the nut radially due to the thread angle of 20°. Lead screws with

such nuts can be used universally, thus also for one-sided “flying” pivoted, long and for fast rotating lead screws. ■

2.2 Threaded spindle fixed on both sides

Usually, lead screws are installed with a “fixed bearing” at one end and a “floating bearing” at the other end – an axially movable bearing. Due to the different spacing between fixed bearing and nut, this produces very different and, for a large spacing, low stiffnesses of the threaded spindle component. In order to increase the stiffness of the “threaded spindle” component, particularly for long spindles and / or high stiffness requirements and to achieve an approximate position-independent stiffness, the threaded spindles are installed with tensile pre-loading in many cases. This tensile pre-loading must be absorbed by the bearings at the end of

the spindle while the spindle is rotating. As the amount of tensile pre-loading is very dependent on the thermal condition of the threaded spindle and the surrounding machine parts, these bearings can be overloaded and destroyed. In order to avoid this danger as far as possible, it is recommended in such cases to cool the hydrostatic oil to room or machine temperature or to a few °C below room temperature. Alternatively, as already described in section 2.3, a rotating nut and stationary spindle can be used, whereby the attachments at the end of the spindle are “overload-proof”. ■

2.3 Rotating threaded spindle or rotating nut?

One reason for the use of a lead screw with a rotating nut are the advantages already described in the previous section of this concept for threaded spindles fixed on both sides.

A second reason arises particularly for high dynamic drives with long threaded spindles if the flywheel mass of the threaded spindle can be reduced by using the rotating nut. However, this is only possible even with optimum design of

the rotating nuts, for threaded spindles with a length of more than approx. 1500 mm.

A third, no less important, reason for the choice of a rotating nut is the avoidance, particularly for long and/or fast rotating lead screws, of the flexural vibrations caused, particularly at critical speeds, by the rotation movement of the spindle.

Alternatively, the rotating nuts can be driven using direct drive (using hollow shaft motor) or by a reduction stage.

The reduction stage can be used for adapting the motor speed to the speed of the lead screw. The hydrostatic rotating nut needs at least one rotating oil supply.

The rotating hydrostatic nut is fitted with an integrated bearing and also needs a rotating oil supply. For cost reasons and also in many cases for space reasons, we recommend using a lead screw with rotating spindle if possible. ■

2.4 Means of fixing the hydrostatic nut for a rotating threaded spindle

Hydrostatic nuts are usually provided as flange nuts: Two supporting nuts on only one side are bolted to a functional unit using an intermediate flange. The dimensions of both nuts and the width of the intermediate flange cannot be changed, however, the external shape of the intermediate flange can be adapted to a large extent to the wishes of the customers.

Here, for example, a choice between a round and a square flange can be made (see section 1; 2).

For the predominantly used size of nominal diameter 50 mm, for example, a “normal size” of the nut for sufficient installation space (see Fig. 1) and a “compact size” for limited installation space (see Fig. 2) are offered.

The hydrostatic nuts are distinguished by the regulator for pocket oil flow control being integrated in the nut so that the user only has to create one oil supply to the nut. These nuts can absorb relatively small radial forces, e.g. the weight of the threaded spindle when installed horizontally. ■

2.5 Lead screw for high slide speeds (with enlarged slope and/or higher speed)

Lead screws with “standard slope” – this is 10 mm for a nominal diameter of 50 mm – are usually designed for a maximum slide speed of 30 m/min (significantly higher speeds can be achieved for short threaded spindles by using oils with lower viscosity).

If higher slide speeds are required, larger thread slopes are used. However, these require higher motor torques for the same infeed forces. Also, less positioning accuracy and

greater track deviations result from the less favourable gear transmission ratio between motor and sled for comparable quality of the motor controller.

The optimal design, not only of the hydrostatic lead screws but also complete feeder axes with calculation of the critical speed, determination of the required drive torques by means of machining, acceleration and weight forces and proposed motor, is offered as a service. ■

3. Advantages of using our PM regulator

Approx. 4 to 5 times the stiffening is achieved with the features of our controller as compared with capillary solutions. As 90 % of the pump pressure can also be used as maximum pocket pressure, this results in a differential pressure at maximum load without reserve of approx. 80 %

of the pump pressure between the left and right nut half. Therefore, it was not possible until using our controller for bearable complexity of the oil supply to develop hydrostatic lead screws with so high stiffness and resilience as the products provided by us. ■

4. Design features

4.1 Oil supply to and oil discharge from the hydrostatic nut, catching the oil and feedback to the hydraulic power unit

The PM regulators for supplying the hydrostatic pockets are integrated in the hydrostatic nuts. The user only has to create an oil supply to the nut and does not have to install any kind of regulation equipment.

Hydrostatic lead screws are usually installed in a slide underneath covers. In these types of cases, the oil can usually discharge at both ends of the nut.

However, in many cases the free discharge of oils cannot be accepted, particularly for fast rotating spindles. A sealing

of the nut has been developed for such cases. However, complete leak tightness cannot be achieved using this seal, in fact small leakage quantities must be assumed. Due to our insufficient experience, the service life of this seal cannot yet be estimated with certainty. As the lead screws are wear-free and this seal is a consumable part whose replacement is not very easy, we strongly recommend our customers to preferably do without this seal. ■

4.2 Self-locking

In contrast to ballscrews, hydrostatic lead screws show self-locking with normal slope a short time after switching off the hydrostatic. When the spindles are used vertically, this results in many essential benefits, particularly for installa-

tion and repair. If the threaded spindle bearing is also hydrostatic, many lead screws also show self-locking with higher slope, as the friction in this bearing increases significantly when the oil supply is switched off. ■

4.3 Installation space and installation position

Due to the character of the hydrostatic lead screw and the PM regulator attached to the nut, the space requirement of hydrostatic nuts is usually greater than that of ballscrews. In spite of this, it has been managed to adapt the external dimensions of the "compact size" of the nut (see Fig. 2) with 50 mm nominal diameter to the flange diameter of the

corresponding ballscrew so that a right-angle channel sufficient for a ballscrew usually also allows the installation of a corresponding hydrostatic nut. This also applies to most other sizes of the lead screw. The installation position of the lead screw is user-defined. ■

4.4 Crash safety

The hydrostatic lead screws are fitted so that they can be overloaded for a very short time in the case of a crash, e.g. slides moving on to the block, without there being contact between the nut and spindle. In this way, damage to the lead screw in the case of a crash is avoided in many cases.

The hydrostatic nut must not be undone from the nut under any circumstances for relaxing these tensions. Instead, the tension must be released by undoing the stop and/or the tensioned parts. ■

5. Technical data

5.1 Main dimensions and technical data

The technical data of the various sizes are compiled in Table 1. The loads stated have been determined by taking account of a load reserve of 50% and the intended maximum pump pressure of 80 bar. In special cases. pump pressures up to

160 bar, i.e. double loading, are possible. The stated maximum thread run numbers are only possible without restriction for normal slope. ■

Table I, dimensions and technical data of the lead screw

Spindle nominal diameter		40	50	63	80	100	125	160	200
External thread - Ø	mm	40	52	65	80	100	128	160	200
Thread core - Ø	mm	27.3	36	45	55.5	70.5	88	112	140
Inside nut - Ø	mm	28	37	46	57	72	90	114	142
Normal slope	mm	8	10	12	15	18	25	25	28
Increased slope I	mm	16	20	25	25	30			
Increased slope II	mm	25	30	40	40	50			
Thread angle	°	20	20	20	20	20	20	20	20
Max thread run number for normal slope		5	5	6	6	6	6	6	6
Effective surface / run	cm ²	4.9	8.1	13.5	18.7	28.5	47.4	74.6	118.8
Spindel core surface	cm ²	5.9	10.2	15.9	24.2	37.9	60.8	98.5	154.0
Max load capacity at 80 bar / run *)	kN	2.2	3.7	6.0	8.4	12.8	21.3	32.6	49
Max load capacity at 80 bar max thread run number")	kN	11	18	36	50	77	128	200	320

Designed/possible lead screw for higher loads

Thread run number		4	6	6	6	6	6	6	6
Pump pressure	bar	120	<i>160</i>	<i>160</i>	<i>160</i>	160	<i>160</i>	<i>160</i>	<i>160</i>
Maximum permitted load	kN	25	<i>85</i>	<i>120</i>	<i>175</i>	300	<i>460</i>	<i>750</i>	

*) With 50% load reserve

5.2 Dimensions of the flange nuts

5.2.1 Flange nut with round fastening flange

Fig. 1 shows a diagram of the flange nut with round fastening flange (without seal).

The main dimensions of the hydrostatic nuts are listed in Table II. D3, D4, X and E can be individually adapted to

customer desires after consultation. The dimensions in italics and the flange nut contour dimensions of the spindle nominal diameters $d=199$ to 200 mm are not binding.

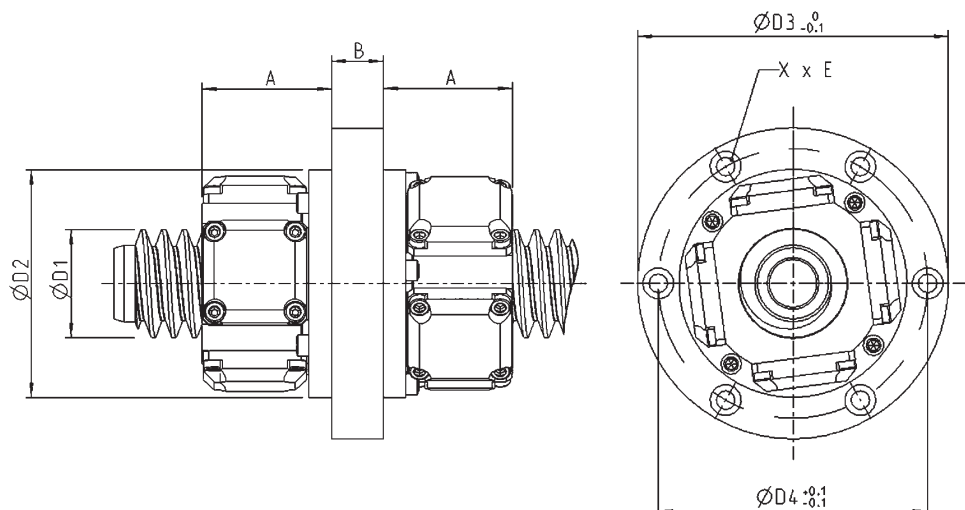

Fig. 1:
Hydrostatic nut with
round fastening flange

Table II, dimensions of the threaded spindle nuts according to Fig. 1 (previous page) (not binding for ND 100 to 200)

Spindle nominal diameter	mm	40	50	65	80	100	125	160	200
D1	mm	40	52	65	80	100	128	160	<i>200</i>
Normal slope		8	10	<i>12</i>	15	<i>18</i>	25	25	28
Increased slope		16	20	25	25	30			
High slope		25	30	40	40	50			
D2	mm	85	110	125	150	185	225	270	
D3	mm	<i>110</i>	<i>150</i>	<i>160</i>	<i>190</i>	<i>230</i>	<i>270</i>	<i>335</i>	
D4	mm	<i>97.5</i>	<i>130</i>	<i>142</i>	<i>170</i>	<i>205</i>	<i>245</i>	<i>300</i>	
A	mm	73	62.5	85	85	90	125	160	
B	mm	20	25	30	40	50	60	80	
E	mm	6.6	9	9	11	13	13	17	
X	Unit	6	6	8	8	8	12	12	

5.2.2 Flange nut with square fastening flange

Fig. 2 shows a diagram of the flange nut with square fastening flange (without seal).

The main dimensions of the hydrostatic nuts are listed in Table III. C, F, X and E can be individually adapted to cus-

tomers desires after consultation. The dimensions in italics and the flange nut contour dimensions of the spindle nominal diameters d= 199 to 200 mm are not binding.

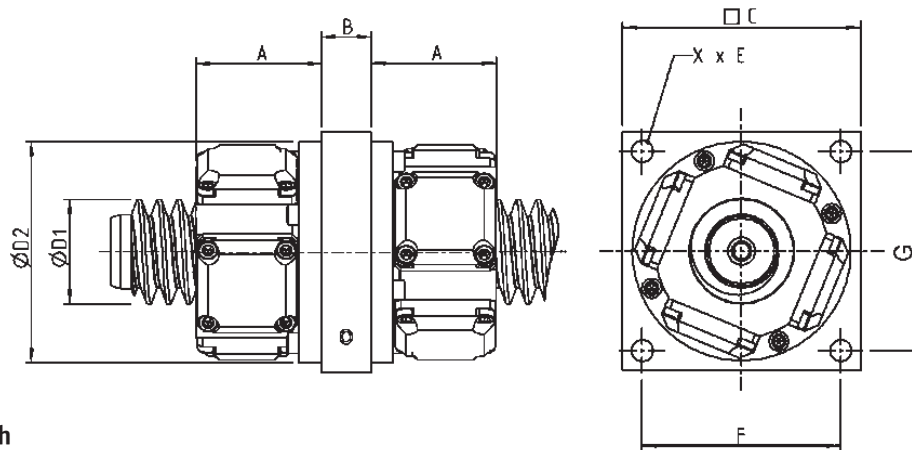

Fig. 2:
Hydrostatic nut with square fastening flange

Table III, dimensions of the threaded spindle nuts according to Fig. 2 (not binding for spindle nominal diameter 100 to 200)

Spindle nominal diameter	mm	40	50	50	65	80	100	125	160	200
D1	mm	40	52	52	65	80	100	128	160	200
Normal slope		8	10	10	12	15	18	25	25	28
Increased slope		16	20	20	25	25	30			
High slope		25	30	30	40	40	50			
D2	mm	85	100	110	125	150	185	225	270	
A	mm	73	70	62.5	85	85	90	125	160	
B	mm	20	25	25	30	40	50	60	80	
C	mm	85	108	120	140	165	200	240	280	
F	mm	73	94	100	120	140	110/175	150/210	180/250	
G	mm	64	70	100	90	105	175/110	210/150	250/180	
E	mm	6.6	9	11	11	13	13	17	17	
X	Unit	4	4	4	4	4	8	8	8	

5.3 Load capacity and stiffness

Possible loads and stiffnesses for six thread runs and 50 % load reserve per nut are given in Table IV for the pump pressure of 80 bar. For different configurations, the possible load capacity can be calculated approximately proportional

to the pump pressure and the thread run number. The stiffnesses can be calculated proportional to the thread run number but only very roughly proportional to the pump pressure. ■

Table IV, load capacities and stiffnesses of the threaded spindle nuts at 80 bar pump pressure, 50 % load reserve and six thread runs per nut

Spindle nominal diameter	mm	40	50	65	80	100	125	160	200
Maximum load capacity	kN	11	18	36	50	77	128	200	320
Axial stiffness	kN/μm	1.2	2.5	4.5	6	9.5	15	25	40

5.4 Some example values for oil supply, leakage power and speed

Examples with extended data, including among other things the required oil flow, the type of oil and oil heating,

the total power leakage at zero speed and maximum speed subject to the maximum speed are listed in Table V. ■

Table V: Technical data from completed and/or planned lead screws (as of 2004)

Spindle nominal diameter		50	50	50	80	160 ²⁾
Maximum speed	RPM	2000	3250	3333	1000	160
Thread slope	mm	10	20	30	25	25
maximum rapid traverse	m/min	20	65	100	25	4
Supporting thread runs	right	5	4	3	5	6
	left	3	4	3	2	4
Load capacity right ¹⁾	kN	10	10	10	50	500
	left ¹⁾	5	10	10	15	320
Axial stiffness of the nut	N/μm	1250	1000	1000	1500	4000
Pump pressure	bar	50	63	63	100	160
Corresponding type of oil		VG32	VG22	VG22	VG68	VG100
Required oil flow at						
Oil temperature 40° C	l / min	1.3	2.8	2.8	4.7	5.8
Friction loss of the nut at						
Maximum speed	W	90	180	180	160	68
Maximum total leakage power (pumps + friction loss)						
at speed 0	W	145	390	390	1050	2000
at maximum speed	W	235	570	570	1210	2070
Oil heating						
at speed 0	°C	4.2	5.2	5.2	8.2	11.8
at maximum speed	°C	10.5	12.0	12.0	14.0	13.0

1) with 50% load reserve

2) with 26% load reserve and maximum 32° C oil temperature

6. Usage and installation of lead screws with hydrostatic nut

6.1 Delivery of the lead screw

The nuts show play on the spindle when the oil supply is switched off, thus also during transport. The play in the axial direction, depending on the spindle Ø and the design, is approx. 30 to 70 μm, and ± 46 to ± 107 μm in the radial

direction due to the thread angle of 20°. In order to avoid damage during transport, the lead screw is usually delivered in a dismantled condition, i.e. with the threaded spindle and nut separated. ■

6.2 Assembly of the lead screw

As there are no loose parts in the nut, the assembly of the spindle into the nut can be performed relatively easily. In order to prevent damage to the nut while doing so, a plastic sleeve, whose external diameter is marginally smaller than the nut internal diameter, must be pushed on to the spindle part, which is inserted first – see Fig. 3. Using this protective sleeve, the spindle is centred as far as possible in the nut.

For lead screws with more than the nominal diameter of 80 mm, we also recommend further guidance of the spindle using the plastic sleeve shown in Fig. 3. Both parts can be obtained from us. When screwing the spindle into the second nut half, the spindle is away from the nut, i.e. pull towards the fitter and then carefully screw in **without forcing**. Screw in nuts from lead screws with nominal diameter

100 mm and larger from below into the vertical hanging threaded spindle.

Every nut is matched to a specific spindle. Therefore, only the nuts and spindles associated with each other must be assembled together. Furthermore, both the supportingflanks of the nut are each matched to a specific flank of the threaded spindle. The nut must therefore only be mounted in the position on the spindle defined by the respective order drawing.

In any case it is identified by the position of the oil supply bore. In many cases the correct position of the nut can be recognised by its asymmetric form.

An order drawing and assembly instructions are included with every lead screw. ■

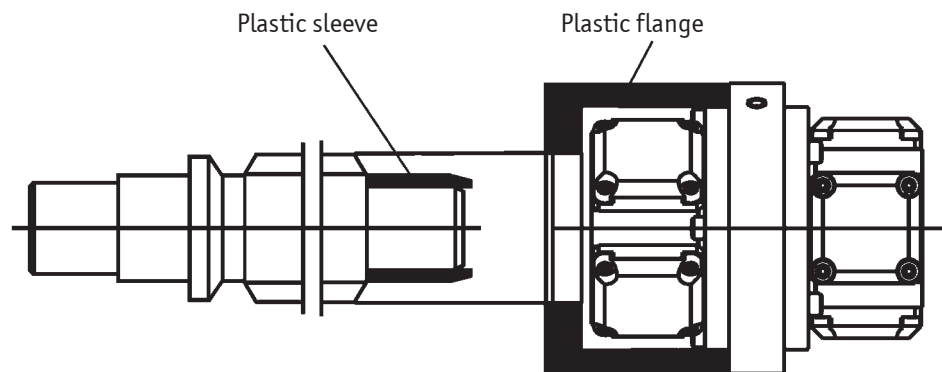

Fig. 3
Installation auxiliary tools

6.3 Installation and adjustment of the hydrostatic lead screw

The nut of the hydrostatic lead screw shows significant play on the spindle when the oil supply is switched off. Thus, unlike the ballscrew whose nut is always centred on the spindle, the hydrostatic lead screw cannot be used as an adjustment tool. Thus, the fixing surfaces on the machine for the nut to the centre of the spindle must be adjusted with-

out the use of the hydrostatic lead screw. If the hydrostatic lead screw is inserted together with a hydrostatic guide, the hydrostatic nut must be aligned centrally to the threaded spindle while the slide is detached (with oil supply switched on for the slide guide). ■

6.4 Installation tolerances for the lead screw

The installation tolerances for the hydrostatic lead screw are comparable with those of a higher quality ballscrew. The

binding permitted tolerances are defined in the respective order drawing. Non binding guidelines are shown in Fig. 4. ■

Tolerance for flange mounting
Toleranz bei Flanschausführung

Tolerance for foot mounting
Toleranz bei Fußausführung

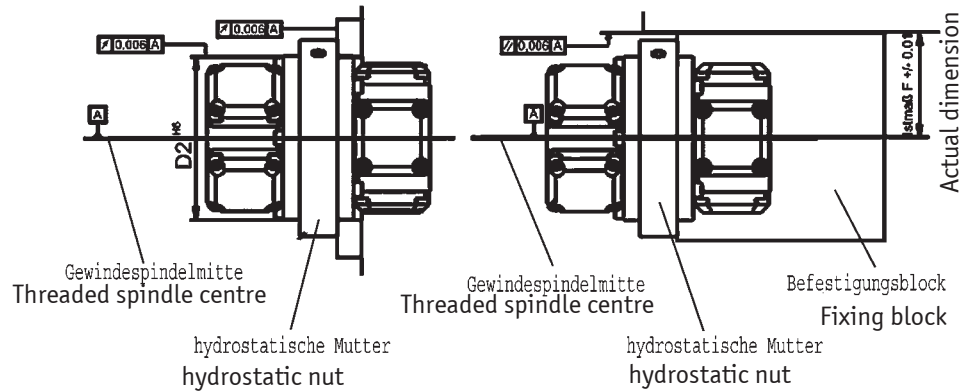

Fig. 4:
Installation tolerances

7. Hydrostatic bearing for lead screw

Hydrostatic bearings for lead screws provide many advantages in comparison with conventional roller bearings.

Advantages of hydrostatic bearings for lead screws:

- unlimited service life as there is no wear
- unlimited acceleration
- no torque jump when changing direction of movement
- frequent reverse operation under high load possible without restriction
- several times improved axial damping
- for very fast rotating spindles

7.1 Bearing for lead screw with 4 regulators

Bearings for lead screws with 4 regulators show three radial and one axial hydrostatic pocket. The bearing can absorb forces in the radial and axial direction, however, no torques.

Advantages of the bearing for lead screws with 4 regulators:

- economic purchase price
- very compact construction for usage with low space requirement
- no transfer of torques to the threaded spindle

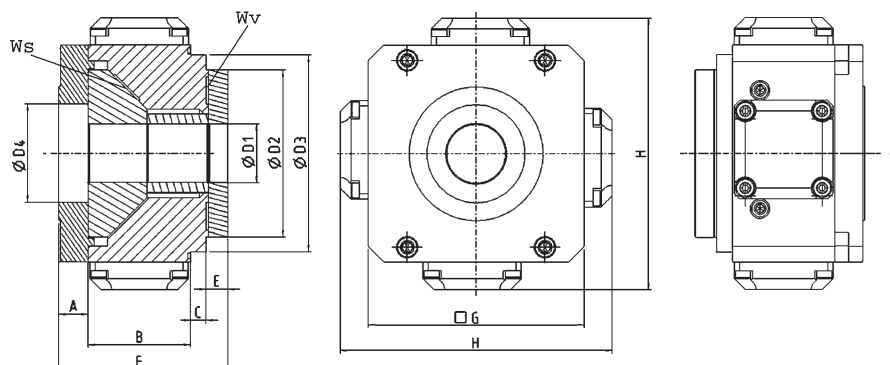

Fig. 5
Hydrostatic bearing with 4 regulators

Table VI: Dimensions bearing with 4 regulators

G	mm	88	110	G	mm	88	110
D1	mm	25	30	C	mm	8	9
D2	mm	71	85	E	mm	10	10
D3	mm	80	100	F	mm	90	86
D4	mm	50	50	H	mm	116	138
A	mm	15	15	Ws	cm ²	22.6	34.4
B	mm	57	52	Wv	cm ²	24.9	36.1

7.2 Bearing for lead screw with 8 regulators

Bearings for lead screws with 8 regulators show two hydrostatic cones pivoted against each other, each of which is pivoted by 90° using four hydrostatic pockets.

The bearings can absorb forces in the radial and axial direction and torques.

Advantages of the bearing for lead screws with 8 regulators:

- can be used for floating pivoted spindles (without counter bearing)
- excellent suitability for very long spindles
- compensation for bending by applying torques

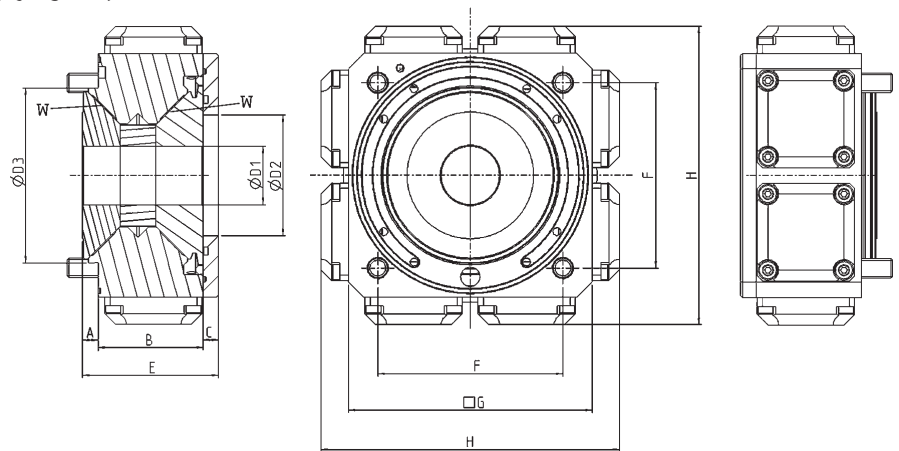

Fig. 6
Hydrostatic bearing
with 8 regulators

Table VII: Dimensions bearing with 8 regulators

G	mm	125	125	135	135	135
D1	mm	30	40	30	40	50
D2	mm	62	62	72	72	72
D3	mm	90	90	100	100	100
A	mm	8	8	8	8	8
B	mm	54	54	54	54	54
C	mm	8	8	8	8	8
E	mm	70	70	70	70	70
F	mm	95	95	112	112	112
H	mm	153	153	163	163	163
W	cm ²	31.0	34.0	45.2	45.2	33.0



HYPROSTATIK®

Advantages of
the hydrostatic
lead screw

Hydrostatic lead screws

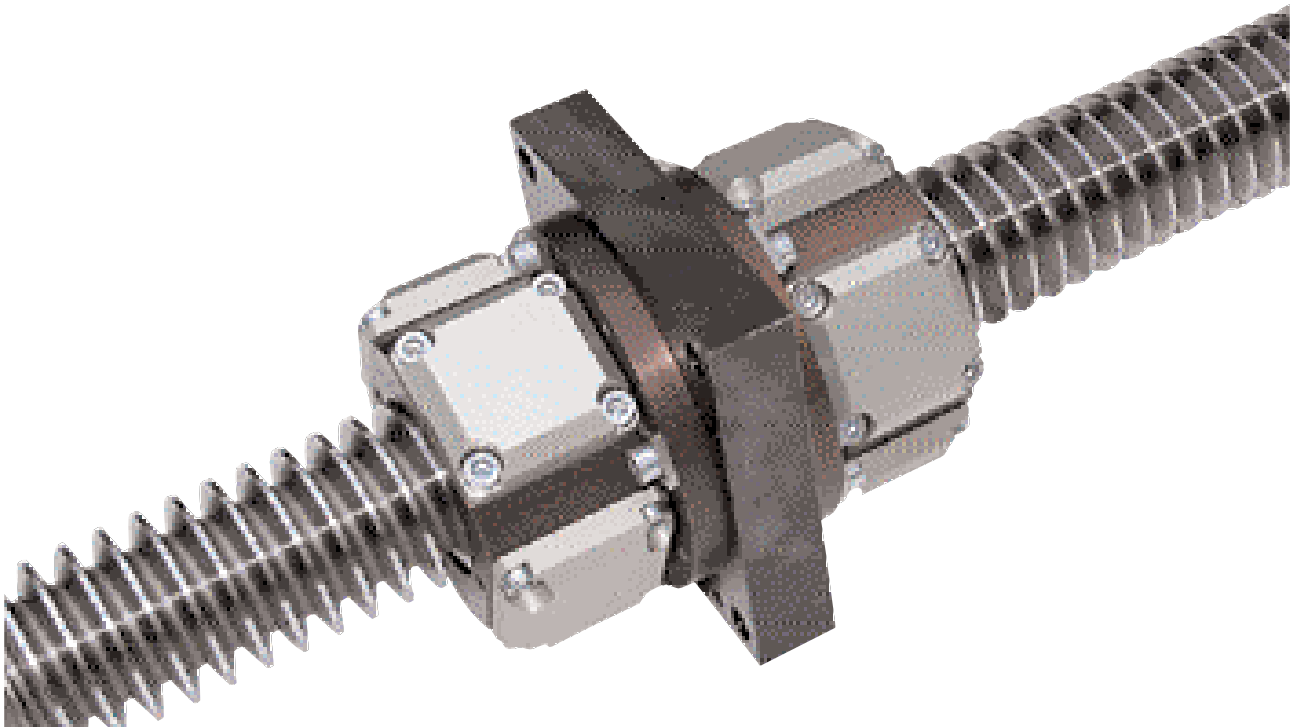

Advantages as compared with ball screws:

- wear-free, as there is no contact during operation
- no loss of precision, even for long operation at full load at maximum speed
- friction free at low speeds
- no friction force jump of any kind during change in rotation direction
- transfers the smallest rotation movements
- no slip-stick effect at low speeds
- no oscillations of the friction torque by ball circulation
- higher axial stiffness than ball screws
- many times better damping, thereby better work piece surface and tool service life
- no vibrations by the ball circulation
- also suitable for high speeds and accelerations
- economic alternative to linear motor with higher precision, many times lower heating, excellent damping and without problems with boring on the permanent magnet

Technical features:

- highly accurate transfer of the rotation to linear movement e.g. for feeder drives
- floating pivoted nut without bearings between hydrostatic pockets
- integrated quantity regulation only by means of the pocket pressure, only one hydraulic connection, no kind of electronic additional control required
- the installation dimensions of the nut are approximated to the dimensions of the ball screw spindle
- spindle ends are designed according to customer wishes

The hydrostatic nut is adapted to:

axial loads in both directions
max. speed, desired stiffness

Hydrostatic bearing for lead screw

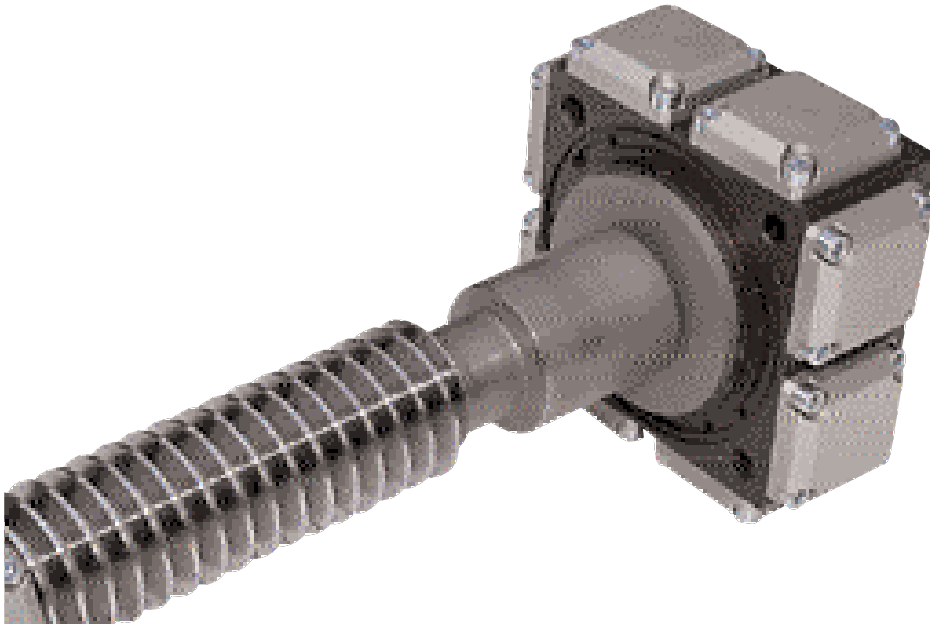

Advantages as compared with roller bearings:

- wear-free, as there is no contact during operation
- no loss of precision, even for long operation at full load at maximum speed
- friction free at low speeds
- no friction force jump of any kind during change in rotation direction
- transfers the smallest rotation movements
- no slip-stick effect at low speeds
- no oscillations of the friction torque by ball circulation
- absorption of axial and radial forces and torques

Technical features:

- suitable for single-sided threaded spindle bearing
- very precise bearing for lead screw
- floating pivoted double ball for bearing in "0-arrangement" between hydrostatic pockets
- integrated quantity regulation only by means of the pocket pressure
- only one hydraulic connection, no electronic additional controller required
- all supply and offtake lines in the flange surface
- optional sealing for one side by positive pressure/ gap ring or sliding seal

The hydrostatic bearing is adjusted to:

- axial force, radial force and torque
- maximum speed
- desired stiffness
- viscosity and temperature of the hydraulic oil

Hydrostatic lead screw

in comparison to linear motor and ballscrew

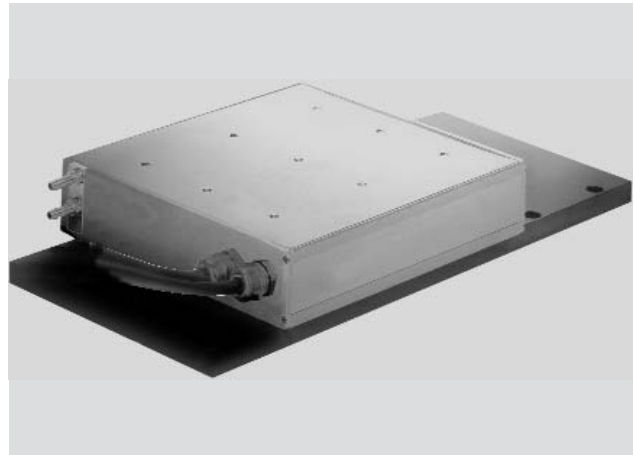
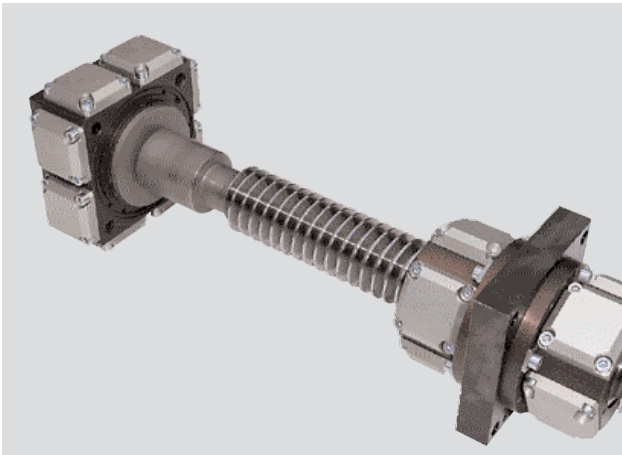

The weakness of ballscrews have resulted in the development of linear motors and high load capacity and wear-free hydrostatic lead screws by the company HYPROSTATIK Schönfeld GmbH. The hydrostatic lead screw is presented and compared with linear motor and ball screw in the following.

While there was already disillusionment if not disappointment after the initial euphoria for some users of linear motors, all of the several hundred hydrostatic lead screws installed, some also in three-shift operation since 1996, have been operating with the highest precision and reliability.

1. The hydrostatic lead screw

Like a ball screw, the hydrostatic lead screw converts the rotary movement of a servomotor into a linear movement. The nut of the lead screw floats on a hydrostatic oil film and is thus absolutely wear-free. Using the oil flows controlled by the PM regulator, the oil film thickness is maintained practically constant irrespective of the speed and load. The play-free hydrostatic nut is extremely stiff and, in spite of this, has very low friction. At low speeds, for example during positioning, the friction is practically zero. The position accuracy, the smallest traverse path and the slowest speed are thus only dependent on the measuring system and the controller. Compared to the dynamic load, the hydrostatic ball screw acts as a shock-absorber with excellent damping. It operates absolutely silently and the well-known vibrations from ballscrews do not occur.

The hydrostatic lead screw is available with rotating spindle or rotating nut in the sizes 40 to 160 mm, for axial forces 10 to 300 kN, speed up to 120 m/min, up to a length of 4 metres in different slopes and with spindle ends manufactured according to customer information. Hydrostatic lead screws are complemented by hydrostatic fixed and floating bearings and guides. ■

2. Physical basic principles

Electrical energy can be converted to mechanical energy very effectively with relatively low forces and high speeds. For this reason, fast running motors with lead screws for producing slow slide speeds and high feed forces are usually used for feeder drives. Thus, the power of the motor is transmitted to the slide via a very large lever. With a corresponding quality of the transfer element, the slide can be delicately adjusted with small forces.

This principle is abandoned by the linear motor. For the direct generation of large forces, extremely strong magnetic fields must be produced, which can only be achieved by electric currents and/or by coils with high inductivity. As coils with current flowing through them represent an electrical mass, a large electrical mass must also be alternately accelerated for dynamic load changes even if the slide only has to be maintained in position. Also, if high voltages are used for changing the magnetic flux, the change in the motor force is time limited.

This problem only exists to a small degree with lead screw and servomotor as the electric currents to be controlled are very much smaller than for the linear motor. ■

3. The stiffness for static and dynamic load

The stiffness of the linear motor resulted exclusively from the position control of the drive in combination with the necessary linear scale. Without positioning control circuit, the stiffness of the linear motor is zero!

In comparison with static load, the stiffness of the linear motor is infinitely high. However, this also applies to a drive with hydrostatic lead screw controlled using a linear scale.

The “dynamic” stiffness of the linear motor is low due to time delays by relocation measurements, reaction time of the controller and build-up of the magnetic field. According to information from one linear motor manufacturer, the dynamic stiffness is between 39 N/μm (for a slide weight of 100 kg) and 120 N/μm (slide weight 600 kg) without mention of the frequencies. There is a danger of resonance oscillations for oscillating slide loading due to the missing damping in the direction of movement.

In contrast, the stiffness of a drive with the hydrostatic lead screw with a nominal diameter of only 50 mm with a spindle length of 400 mm is 350 to 400 N/μm and significantly higher if the spindle is clamped on both sides.

Together with the high damping and the higher total mass of the feeder axis of the hydrostatic lead screw resulting from the inertia torque of the spindle, several times smaller oscillation paths or dynamic position deviations are achieved with this drive than with the linear motor. Path oscillations of the hydrostatic lead screw also die away very quickly due to the excellent damping. ■

4. The maximum acceleration

There are no component conditional acceleration limits for the hydrostatic lead screw and linear motor. The maximum acceleration is limited by inertial forces and feed pressures. The service life of the hydrostatic lead screw is not reduced by the acceleration.

The servomotor must also accelerate its own inertia torque and that of the lead screw. Nevertheless, modern servomotors can accelerate 500 or 1000 kg heavy slides with traverse lengths of 500 or 1000 mm at 16 to 34 m/s².

Significantly higher acceleration values are also possible for optimised short-stroke slides. ■

5. The feed pressure

The maximum continuous feed pressure of approx. 8 kN of the largest linear motor is not sufficient for a large part of the applications in machine tool manufacturing. With hydrostatic lead screws of the size 50 mm, up to 20 kN can be applied and up to 300 kN with the size 125! ■

As regards the possible feed pressures, the hydrostatic lead screw is far superior to the linear motor! High loads even with very slow, extremely fast or oscillating movement do not adversely affect the function and service life of the hydrostatic lead screw in any way. ■

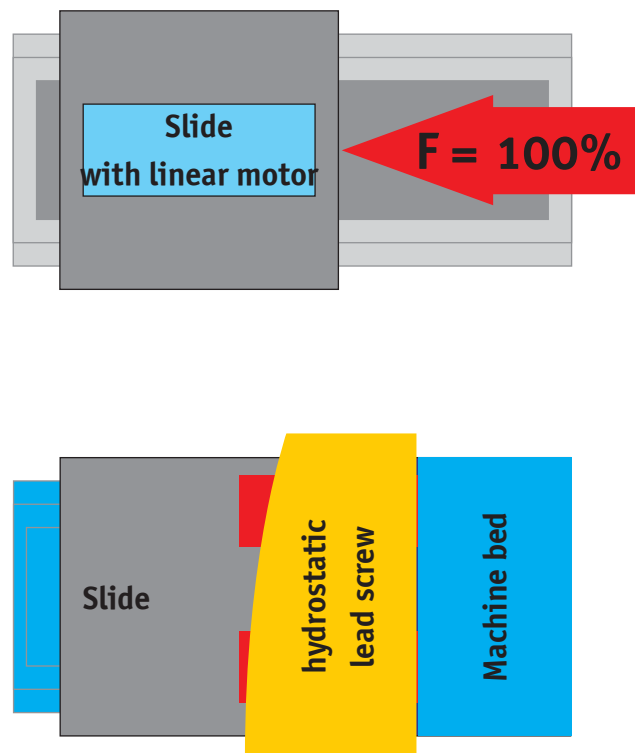

6. The maximum slide speed

The maximum speed with the hydrostatic lead screw is

- approx. 40 m/min with 10 mm slope,
- up to 80 m/min with 20 mm slope,
- up to 120 m/min with 30 mm slope.

With a rotating spindle, the maximum speed is limited by the critical speed, however, hardly at all when using a rotating nut.

The maximum slide speed of the linear motor at rated load is stated as 60 to 200 m/min accelerations. However, it is limited when using the linear motor by the safe management of the kinetic energy of the slide also in the case of a power cut, the risk of destruction during a crash and by the possible risk of accident. ■

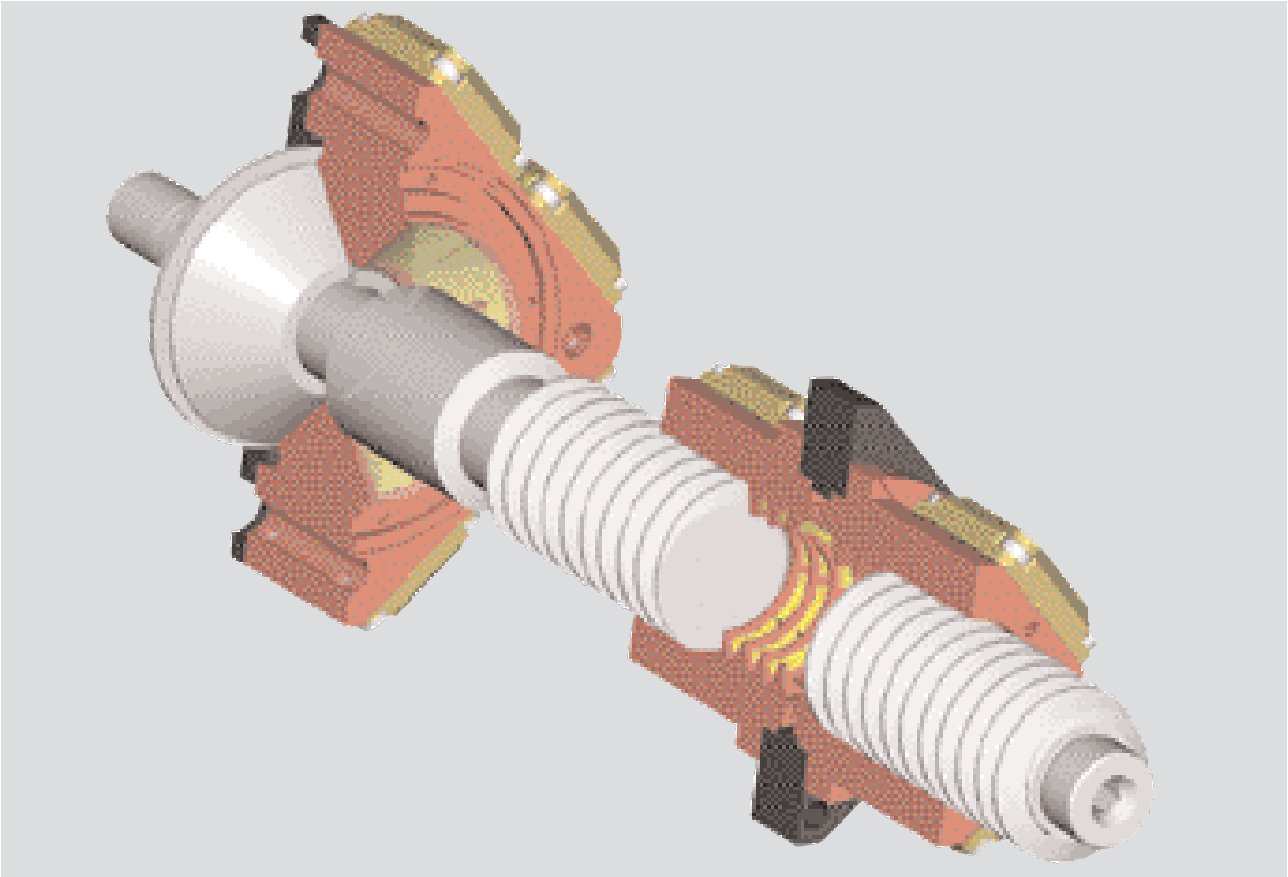

7. Usefulness of high accelerations and speeds

For most machine tools, high slide speeds and accelerations are not needed during the machining process, but only for reduction of the auxiliary process times.

Reduced auxiliary process times using higher acceleration than 10 m/s^2 for average processing times are only somewhat expedient. Higher accelerations should then only be provided if they are necessary for the machining process or for extremely short processing times.

Increasing the speed of the slide from 20 to 40 m/min is expedient. A routine fast track of approx. 400 mm should be traversed for a further increase from 40 to 60 m/min. An increase to 80 m/min only appears to be expedient for routine fast tracks greater than approx. 800 mm.

Acceleration of 20 m/s^2 and speed of 120 m/min can be achieved with the hydrostatic lead screw. For most machine tools, it makes sense to achieve better machining results, longer service life, lower range of temperature, reduced maintenance and electricity costs with slightly lower speeds and accelerations. ■

8. Energy requirement, heat input, cooling

For most machinings, a low slide speed of approx. 0.1 - 0.4 m/min and a high feed pressure are required during the primary processing times, which require the most time.

The cooling capacity of our comparison linear motor for these low feeder speeds with 6,600 N nominal force is **5.4 kW** according to the manufacturer information. A cooling unit capacity of approx. **2.1 kW** is needed for recooling this capacity. Thus, altogether approx. **7.5 kW is needed while a feed pressure of only 6,600 N is achieved!**

A typical hydrostatic lead screw for higher speeds requires an oil flow of approx. 2.0 l/min at e.g. 50 bar pump pressure. A capacity of approx. **0.45 kW** for driving the pressure pump and the air-oil heat exchanger and a capacity of **0.14 kW** for the servomotor at 400 mm/min feeder speed, 10,000 N feed pressure and 50 % efficiency are needed. Thus there is a power requirement of approx. **0.6 kW**.

A much higher feed pressure, but leakage power reduced by 6.9 kW as compared with the linear motor!

For average usage with only one single axis and an electricity price of 0.08 Euro / kW and 2000 operating hours per year, there would be estimated additional costs of 750 Euros per year and 2.250.080 Euros per year for three-shift operation. **If these costs are capitalised with a rate of**

12 % for interest and depreciation, these costs equate to investments of **6,250 Euros** or **18,750 Euros per axis**. Even with a few machines with linear motors, additional costs for the power supply, e.g. for a separate transformer station, are probable. Thus, the energy costs must absolutely be taken into account for a comparative examination.

The linear motor must usually be arranged under the slide. The enormous heat output of the motor must be kept away from the slide by water cooling and insulation, otherwise the heat input results in unacceptable inaccuracies.

In contrast, the servomotor of the hydrostatic lead screw is usually arranged outside the axis so that the heat transfer to the axis is minimal. Thus, an external fan is usually sufficient for the motor cooling; water cooling is only required in special cases. The energy input to the oil by pump and friction of the hydrostatic nut is typically, even for fast slide movements, only approx. 60 to 120 Watt and is predominantly discharged with the oil. The oil continuously tempers and cleans the threaded spindle. An air-oil heat exchanger is only needed for high slide speeds and/or high demands on the thermal stability of the machine. ■

9. Comparison with ball screw

No very high accelerations and also no extreme speeds and oscillating movements are possible with ball screws for an acceptable service life, particularly on account of the ball deflection.

The ball screw has only minimal damping and wears, whereby position dependent differences for friction, stiffness and changeover jump are produced.

In the case of a crash, ball impressions can be produced on the tracks, which force premature replacement of the ball screw spindle.

A significant torque jump occurs when changing the direction of movement due to the pre-tensioning of the nut. The friction torque of ball screws varies due to the ball run-in and run-out. Due to this torque jump and its different size, precise position control, the defined traverse of small paths and moving at very low speeds are only conditionally possible with the ball screw.

The hydrostatic lead screw does not show all these disadvantages! Acceleration with hydrostatics is not limited and the hydrostatic nut can be optimally designed for every application by selection of oil viscosity, pressure and flow rate. The hydrostatic lead screw is wear-free, slow movements (also with high load and oscillating movements) are no problem for the highest frequencies and oscillation speeds. The damping of path vibrations by the hydrostatic nut is magnificent. ■

The crash safety is far higher than that of the ball screw, however, the hydrostatic lead screw can be damaged by a crash.

As measurements by the “Werkzeugmaschinen und Betriebstechnik (machine tools and operating technology)” have shown, the stiffness of the hydrostatic lead screw is significantly higher than that of comparable ball screws and does not change by wearing. Despite this, the hydrostatic lead screw friction is very small and also proportional to the rotation speed, whereby no torque jump of any kind occurs when changing direction.

If hydrostatic bearings are also used at the ends of the lead screw and the slide is guided hydrostatically, the servomotor thus has no friction of any kind to overcome even at low speeds and when changing the direction of movement. The hydrostatic drive and guidance system thus also enables the gradual and oscillating traverse of the slide by fractions of μm and extremely slow traverse, which are of course completely independent of the load. ■

10. Vertical axes, power cut

Braking the linear motor, even with a brake van, is problematic in the case of a power cut or motor failure.

In contrast, with the integrated brake in the servomotor, **much higher braking forces** can be applied via the hydrostatic lead screw.

In addition, the lead screw with normal slope (nominal size 50, 10 mm slope) has the advantage over the ball screw of self-locking when the hydrostatic oil supply is switched off. For dynamic vertical axes without weight compensation, the linear motor needs much higher amounts of energy to stop the mass than the drive with lead screw (see point 8). ■

11. Guides

The guides of linear motor axes are strongly **charged with high magnetic forces**, the forces also have an effect even when the machine is switched off. This load varies and is a multiple of the maximum motor power, in comparison approx. 40 kN. In conjunction with high speed and acceleration, the service life of roller guides is reduced.

Thus, multiple hydrostatic guides instead of roller guides are used for linear motor slides.

Like the lead screw, the hydrostatic guides operate **absolutely wear-free** and have a 20 to 1000 times lower friction force proportional to speed and independent of load.

There is **no force jump** of any kind by the guide when the direction of movement changes. Thus, for a corresponding

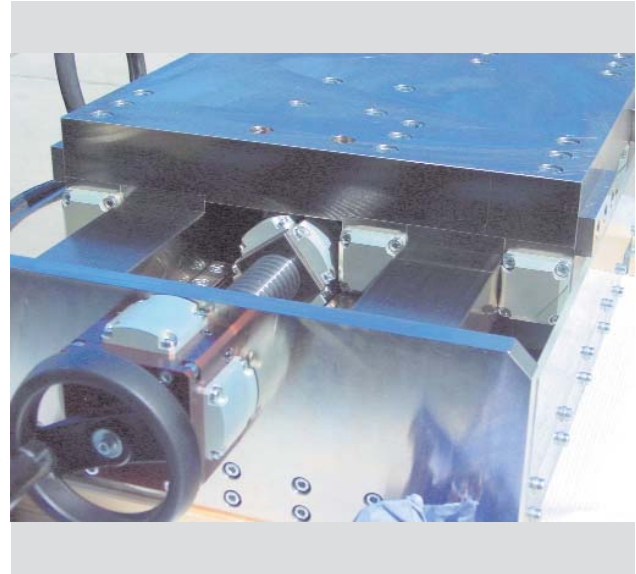
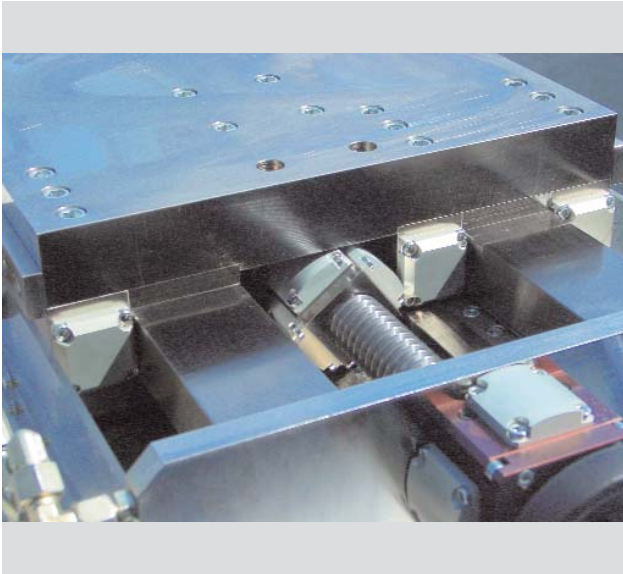

quality of the drives and control systems, gyrations with path deviations in the range of $0.1 \mu\text{m}$ are possible with “completely hydrostatic” cross slides, whereby completely new machine concepts are possible, e.g. jig boring machines, coordinate grinding machines. ■

12. Special features of linear motors and hydrostatic lead screws

Magnetic chips are attracted by the strong magnetic fields of the linear motor components and can cause faults later. Therefore, better covers are needed for linear motors.

The installation, maintenance and replacement of the linear motor integrated in the machine are significantly more complex than for the externally attached servomotor, which can be replaced **without dismantling the axis**.

Due to the strong magnetic fields of the linear motor, **additional measures for the protection** of certain groups of people (for example, those with heart pacemakers, metal implants or pregnant women) and objects, which can be affected by magnetic fields (data media, watches, credit cards) are required.

The high permanent magnetic forces also cause problems during installation: The motor suppliers recommend always keeping some non-magnetic wedges available during installation so that the motor components can be separated from each other in the case of an accident!

In addition, the machine manufacturer is bound to the linear motor manufacturer, which in many cases results also in liaison with only one control system manufacturer.

The oil necessary for operating the hydrostatic lead screw must be fed back into the power unit. Either it is fed back into a pipeline by a nut fitted with a wiper ring or it flows back into the tank together with the hydrostatic guide oil. The

same oil at the same pressure from the same power unit can be used for the guide, the lead screw and the lead screw bearing and can still be used for other hydraulic or lubrication tasks.

Machines must be completely redeveloped for using with linear motors.

Hydrostatic lead screws with low complexity can be used instead of ball screws. If the somewhat larger nut of the hydrostatic lead screw is taken into account during the new design, the customer can optionally choose a ball screw or the hydrostatic lead screw. ■

13. Price comparison

A correct comparison of prices is dependent on the details. As compared with the ball screw, additional costs for the hydrostatic lead screw accrue due to the lead screw and negligible ones from the power unit and cover.

In most cases, the hydrostatic lead screw with servomotor is significantly more economic than the linear motor, which causes much higher costs mainly due to the costs for motor components, cooling plates, peripheral equipment, linear scale, complex control system, large cooling power units and the modified or new design of the machine.

Most of the lead screws installed to date **have significantly reduced the costs for the machine users as the hydrostatic lead screw in 3-shift operation even after more than 5 years is as good as new**, whereas a ball screw in this period would possibly have been replaced several times. For long traverse paths, the linear motor is more expensive due to the permanent magnets. ■

14. Applications

Nine years after the first delivery, there are today approx. 250 lead screws installed per year as the standard in many important, European cam, crankshaft, universal, ultra precision and cog wheel grinding machines.

Noncircular machinings with over 60 Hz and 3,000 rpm at the work piece have been realised. Lead screws with 340 kN axial force and 3.5 m long machine internal gear tooth forming in broaching machines for automatic gearboxes.

There is a milling machine in the "Machine Tool Research Center" in Florida, which is fitted with hydrostatic lead screw and guides.

The Fraunhofer IPT in Aachen uses hydrostatic lead screws, fixed and floating bearings and hydrostatic guides in an ultra precision machine. ■

15. Summary

Ball screws are limited in positioning accuracy, stiffness, acceleration, speed, load capacity and service life.

In the wide range of applications for machining and rapid traverse speeds up to 80 m/min, the hydrostatic lead screw is technically and economically superior to the linear motor.

The alternative to the ball screw and linear motor is the hydrostatic lead screw. It reaches speeds up to 120 m/min, accelerates like a linear motor, however, has a 10 times less energy consumption for the typical infeed for machine tools.

With the same acceleration, the hydrostatic lead screw provides multiple feed pressures in comparison. It has excellent damping, a linear scale is not absolutely necessary.

The dynamic stiffness of the linear motor of 30 to 120 N/ μ m is very low. The stiffness of a hydrostatic lead screw nut nominal size 50 mm and of the fixed bearing is 1,200 - 2,000 N/mm, the dynamic stiffness is even higher. The required oil flow rate of 1-2 l/min for the hydrostatic nut can be fed back with little complexity.

With hydrostatic guides, both systems can position very precisely, however, the linear motor has problems with maintaining the position during impacts and dynamic loads.

The enormous leakage power of linear motors results in very high temperatures under the slide, it must be cooled with large and expensive cooling equipment.

Metal chips are held by the permanent magnets and can damage primary and secondary parts. The same chips on the hardened non-magnetic lead screw in contrast are pushed away.

The hydrostatic nut cleans and tempers the screw continuously.

The linear motor permanent magnet forces on the roller guides result in premature wear if no hydrostatic guides are used.

There are significant dangers from the linear motor components during installation.

A servomotor of an hydrostatic lead screw is easy and significantly less complex to replace than a defective linear motor. Motors and control systems from different manufacturers can be used on the same machine with lead screws.

Apart from some HSC machines where high speeds and accelerations are required, acceleration values of more than 10 m/s² only make minimal time savings possible, extreme values of the speed more than approx. 20 to 30 m/min only permit small time savings (in many cases, this saved time does not justify the extra cost for suitable machines, particularly those for higher accelerations).

The euphoria with which the electric linear motors were greeted does not, however, seem understandable in view of the facts described above. ■

We therefore recommend to also consider the classic feeder drive with lead screw and hydrostatic nut and also hydrostatic axial bearings for the threaded spindle as alternatives to the linear motor!



HYPROSTATIK® Schönfeld GmbH

Felix-Hollenberg-Str. 3 73035 Göppingen

Tel: +49 (0) 71 61/ 96 59 59-0 · Fax -20

Email: info@hyprostatik.de

www.hyprostatik.de